



VCW SERIES

First-In First-Out Chip Warmers



Model VCW46



SPECIFIER STATEMENT

First-in, first-out high volume chip warmer Vulcan Model Nos. VCW26 and VCW46. VCW26 holds 26 gallons of chips while model VCW46 holds 46 gallons of chips. Internal baffles to minimize chip breakage. Fan circulates air for even heat distribution and quick heating of the chips. Fully removable front panel and bottom baffle allows for full access to the interior of the unit for quick and easy cleaning. Top doors, front panel and bottom baffle are removable without tools. Top filled doors open wide for easy loading of chips. Front door serves as a shelf when scooping chips and the sloped front allows secure closure and easy opening. Unit comes with illuminated on/off switch and adjustable rear-mounted thermostat (90°-190°F). Durable 20 gauge stainless steel construction with 12 gauge front door hinge and high density insulation. Furnished with power cord and a NEMA 5-15 plug, 120 volt, 1,000 watts / 8.3 apms (VCW26) 1,500 watts / 12.5 amps (VCW46). One year limited parts and labor warranty. After the first year, lifetime parts warranty on the heating elements and drawer rollers.

Exterior Dimensions:

VCW26: 26½"W x 30½"D x 30½"H

VCW46: 26½"W x 30½"D x 38"H

UL Listed. UL Listed to Canadian safety standards, Classified by UL to NSF Standard #4.

Project _____

AIA # _____ SIS # _____

Item # _____ Quantity _____ C.S.I. Section 114000

MODELS

VCW26 26 gallon chip warmer

VCW46 46 gallon chip warmer

STANDARD FEATURES

- Capacity 26 gallons for model VCW26 and 46 gallons for model VCW46
- Door opens creating a shelf for scooping chips
- Sloping front of unit allows secure closure and easy opening
- Wide top opening doors for easy loading of chips
- Fan circulates air for quick and even heating of chips
- Internal baffle minimizes chip breakage
- Fully removable front panel and bottom baffle for quick and easy cleaning of the unit
- Top doors, front panel and bottom baffle are removable without tools
- Durable 20-gauge stainless steel construction with high density insulation
- 12-gauge front door hinge
- Adjustable rear-mounted thermostat (90°-190°F)
- Illuminated on/off switch
- 4"-5" adjustable legs
- Furnished with power cord and a NEMA 5-15 plug
- VCW26: 120 volt / 1,000 watts / 8.3 amps
VCW46: 120 volt / 1,500 watts / 12.5 amps
- One-year parts and labor warranty
Ten-year element warranty

VCW – First-In First-Out Chip Warmers

Approved by _____ Date _____ Approved by _____ Date _____

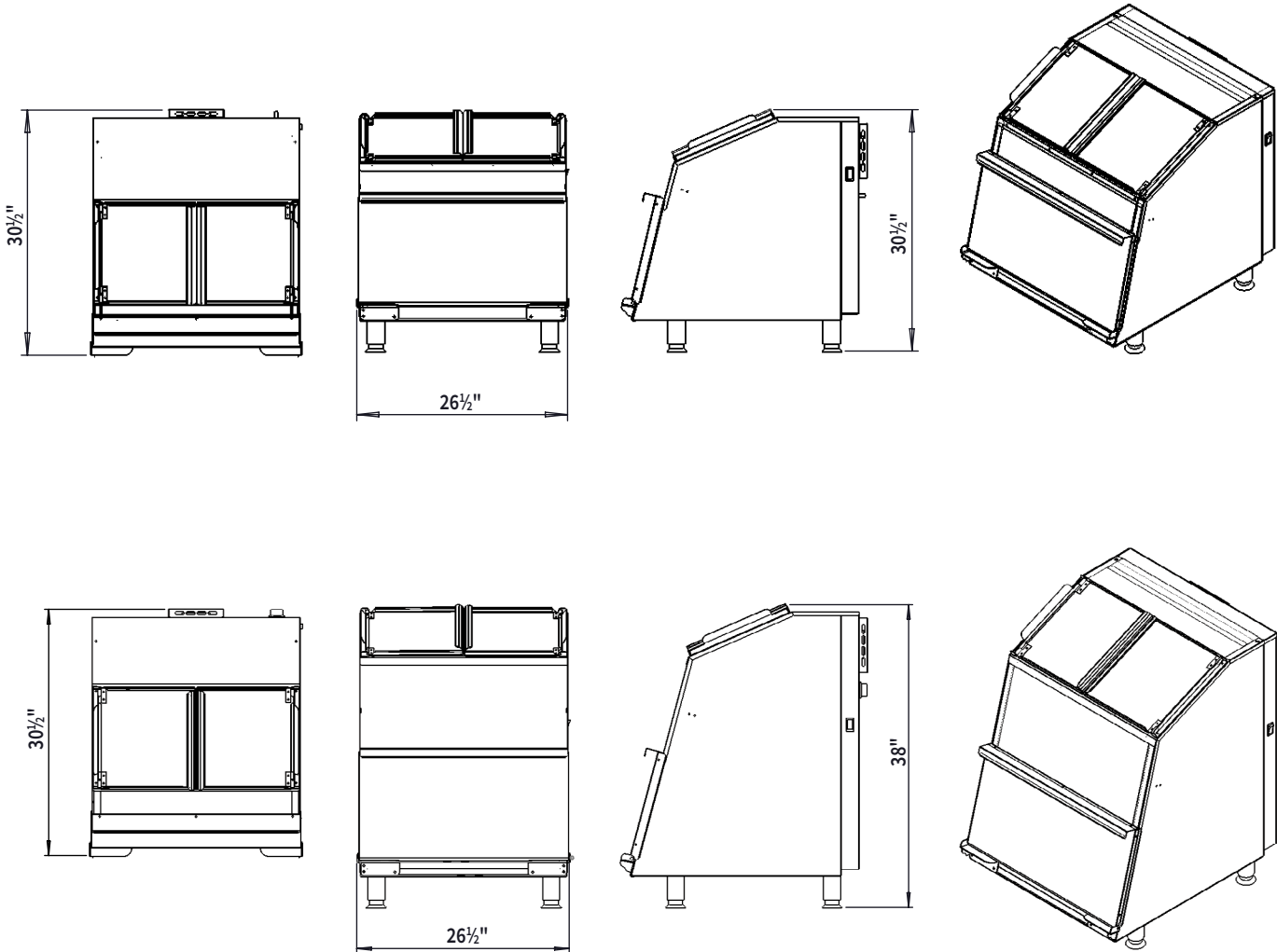

➤ CAD and/or Revit Files Available

INSTALLATION MANUAL

This appliance is manufactured for commercial use only and is not intended for home use.

Model	Capacity	Dimensions			Shipping Weight	Electrical		
		High	Deep	Wide		Volts	Watts	Amps
VCW26	26 gallons	30½"	30½"	26½"	115 lbs.	120	1000	8.3
VCW46	46 gallons	38"	30½"	26½"	153 lbs.	120	1500	12.5

As continued product improvement is a policy of Vulcan, specifications are subject to change without notice.